

CAD FILE:

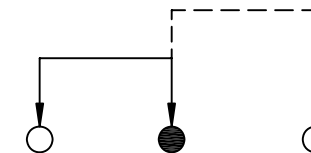

**SCHEMATIC (SHORTING)**

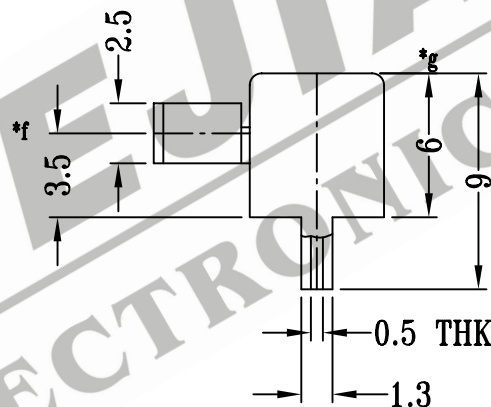
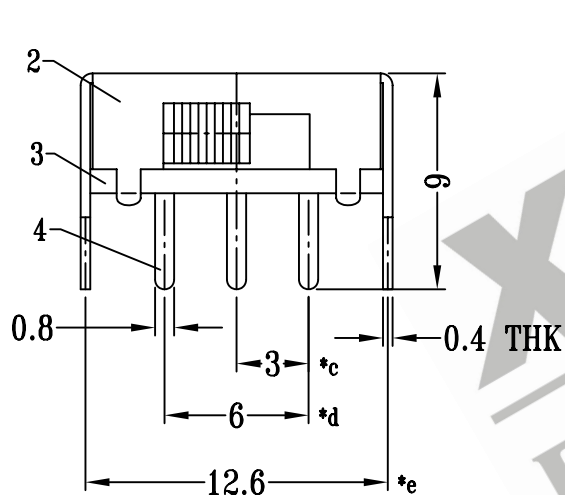
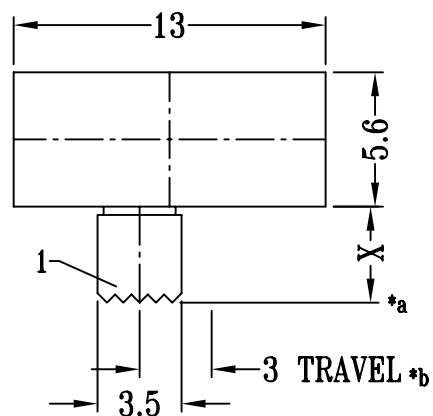
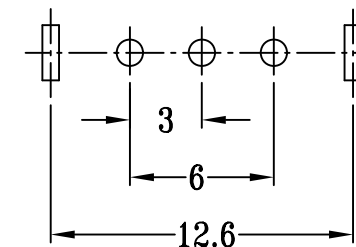

**P.C.B LAYOUT**

注:带"\*"表示关键尺寸(7个)

NO.	PART NAME	MATERIAL	Q'TY	FINISHING	TOLERANCE UNLESS SPECIFIED	SHENZHEN XIEJIA ELECTRONICS CO.,LTD.																															
8						<table border="1"> <tr> <td>ISSUE</td> <td>DATE</td> <td colspan="2">DESCRIPTIONS</td> <td>APPD.</td> </tr> <tr> <td colspan="2">TITLE : HORIZONTAL SLIDE SWITCH</td> <td>UNIT : MM</td> <td colspan="2">DRWG NO.: XJ-DR-SK12E12-00</td> </tr> <tr> <td colspan="2">MODEL: SK-12E12</td> <td>SCALE: 3:1</td> <td>DWN.</td> <td>ZHOUYU</td> <td>2001-4-5</td> </tr> <tr> <td colspan="2">ALL MATERIALS MUST BE COMPLIANT TO ROHS</td> <td></td> <td>CHK'D</td> <td>FANGYING</td> <td>2001-4-5</td> </tr> <tr> <td colspan="2"></td> <td></td> <td>APPD.</td> <td>KANGXINAN</td> <td>2001-4-5</td> </tr> </table>				ISSUE	DATE	DESCRIPTIONS		APPD.	TITLE : HORIZONTAL SLIDE SWITCH		UNIT : MM	DRWG NO.: XJ-DR-SK12E12-00		MODEL: SK-12E12		SCALE: 3:1	DWN.	ZHOUYU	2001-4-5	ALL MATERIALS MUST BE COMPLIANT TO ROHS			CHK'D	FANGYING	2001-4-5				APPD.	KANGXINAN	2001-4-5
ISSUE	DATE	DESCRIPTIONS		APPD.																																	
TITLE : HORIZONTAL SLIDE SWITCH		UNIT : MM	DRWG NO.: XJ-DR-SK12E12-00																																		
MODEL: SK-12E12		SCALE: 3:1	DWN.	ZHOUYU	2001-4-5																																
ALL MATERIALS MUST BE COMPLIANT TO ROHS			CHK'D	FANGYING	2001-4-5																																
			APPD.	KANGXINAN	2001-4-5																																
7																																					
6	CONTACT CLIP	BRASS STRIP	1	Ag PLATED	WITHIN: 1.5±0.1mm OVER : 1.5±0.2mm																																
5	SPRING	STEEL WIRE	1	TEMPER																																	
4	TERMINAL	BRASS STRIP	3	Ag PLATED OVER Ni PLATED																																	
3	BASE	PHENOLIC RESIN	1	NATURAL																																	
2	FRAME	STEEL STRIP	1	Ni PLATED																																	
1	KNOB	POM	1	BLACK																																	